

## HT28 RTJ PRO



### PERFORMANCE & PRODUCTIVITY

- > Industry leading horizontal outreach of 23.85 m
- > Smooth and precise movements
- > Outsanding RT capacities
- > Dual load 230 - 350 kg (optional)

### SAFETY & COMFORT

- > Haulotte Activ'Shield Bar 2.0
- > Haulotte Activ'Lighting System for safe loading / unloading in conditions of low visibility
- > Ultimate control & comfort is engineered to provide superior working-envelope efficiency
- > Rugged boom design

### COST EFFICIENCY

- > Haulotte Activ'Screen (on-board diagnostic)
- > Haulotte Stop Emission System which regulates engine run time, reducing fuel consumption, pollution, and noise
- > Modular platform quick and easy to repair
- > Easy access to all components



# HT28 RTJ PRO

ROUGH TERRAIN  
TELESCOPIC BOOMS

## TECHNICAL DATA

### HT28 RTJ PRO

Working height	27.9 m
Platform height	25.9 m
Horizontal outreach	23.85 m
Below ground reach	3 m
Lift capacity	230 kg (2 pers.) - option 350 kg
<b>F</b> x <b>G</b> Platform size	2.44 x 0.91 m
<b>A</b> Length - stowed	13.05 m
<b>H</b> Length storage / transport	9.8 m
<b>B</b> Overall width	2.48 m
<b>C</b> Height - stowed	2.85 m
<b>I</b> Height - storage / transport	2.98 m
Vertical jib rotation	133° [- 66° / + 67°]
Jib length	1.83 m
Turntable rotation	360° continuous
Tailswing	150 cm
<b>D</b> Wheelbase	2.80 m
<b>E</b> Ground clearance	48 cm
Tilt	4 °
Drive speed	0.5 - 5 km/h
Gradeability	45 %
Turning radius - outside	4.35 m
Engine	Kubota, 53 kW, Turbo, Stage 5 *NRC: Kubota, 49.2 kW, Turbo, Stage 3A
Weight	18 100 kg

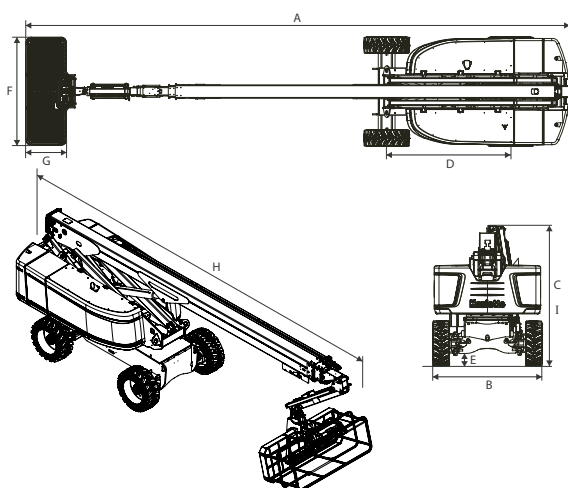

\*NRC: Non Regulated Countries

## STANDARD EQUIPMENT

- > Haulotte Stop Emission System
- > Haulotte Activ'Screen: on-board diagnostic
- > Haulotte Activ'Shield Bar 2.0
- > Haulotte Activ'Lighting System
- > Universal telematics plug
- > 4 wheel drive / 4 wheel steer
- > Oscillating axle
- > Smooth & proportional movements
- > Automatic wheel differential lock
- > Upper control box protection cover and tool tray in ultra-rugged composite
- > Large modular platform 2.44 x 0.91 m
- > Drop bar entry gate
- > Basket rotation 180° (± 90)
- > Swing out engine tray for easy maintenance access
- > Sound and light alarm for tilt and load
- > Motion alarm and rotating beacon light alarms

## OPTIONS AND ACCESSORIES

- > Non-marking tyres
- > Dual load capacity 230 - 350 kg (2 persons)
- > 60 km/h wind speed
- > 110 / 230 V power to platform
- > 1/2 in air line to platform
- > Lateral swing door entry gate
- > Hydraulic generator 3.5 kW or 6.5 kW
- > Work light package
- > Hydraulic oil cooler
- > Cold weather package / arctic weather kit
- > Pipe rack kit
- > Glazier kit
- > Motion flashing warning light
- > Battery circuit breaker

