

58ZT



Concrete solutions. Always.

Engine V2607-CR-T

Engine power 45,0 kW - 61,2 HP

Operating weight 5.400 kg

 **EUROCOMACH**[®]

58zT

Operating weight (with rubber tracks)	kg	5.400
Travelling speed (AUTO TWO SPEED)	km/h	1a: 0 ÷ 2,5 / 2a: 0 ÷ 4,5
Slew speed	rpm	11

ENGINE

Type	KUBOTA V2607-CR-T - STAGE 5	
Max Power (2.200 rpm)	kW - HP	45,0 - 61,2
Displacement	cc	2.615
Number of cylinders	n°	4
Cooling	water	
Consumption	lt/h	7,6
Alternator	V (A)	12 (60)
Battery	V (Ah)	12 (95)

HYDRAULIC SYSTEM

Circuit Type	load sensing closed center system with flow sharing control valve	
Pump type	1 ls variable pump + 1 gear pump	
Pump displacement	cc	65 + 14,5
Pump capacity	lt/min	129 + 28,8
Max. circuit calibration pressure	bar	280
Auxiliary Flow (max pressure):	lt/min (bar)	80/80 (200)
AUX 1 main high flow simple or double effect		

PERFORMANCES

Max digging depth standard arm (optional arm)	mm	3.400 (3.570)
Max dumping height with cab standard arm (optional arm)	mm	3.950 (4.050)
Bucket breaking force (standard arm) ISO 6015	daN	5.300
Arm breaking force (standard arm) ISO 6015	daN	2.800
Traction force	daN	5.500
Ground bearing pressure with rubber tracks	kg/cm ²	0,31
Max slope	60% - 30°	

DIMENSIONS

Maximum width	mm	1.980
Total height	mm	2.550
Rear rotation radius	mm	1.000
Digging arm length std (optional)	mm	1.500 (1.650)
Tracks width	mm	400
Rollers number (for each side)	n°	5/1

FILLINGS

Fuel tank	lt	85
Hydraulic oil tank	lt	60
Hydraulic circuit capacity	lt	80
Cooling system capacity	lt	12
Engine oil	lt	10,2

CONTROLS

Boom, dipper stick, bucket and turret swing	2 pilot joysticks
Tracks movement (included counter rotation)	2 pilot levers
Dozer blade	pilot lever
Auxiliary circuit (simple or double effect)	electroproportional switch on right joystick
Boom swing	electroproportional switch on left joystick

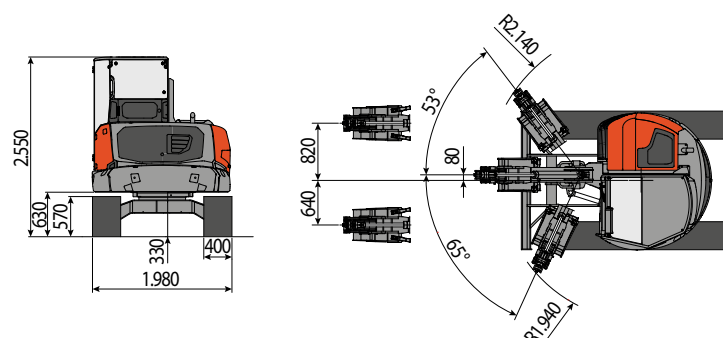
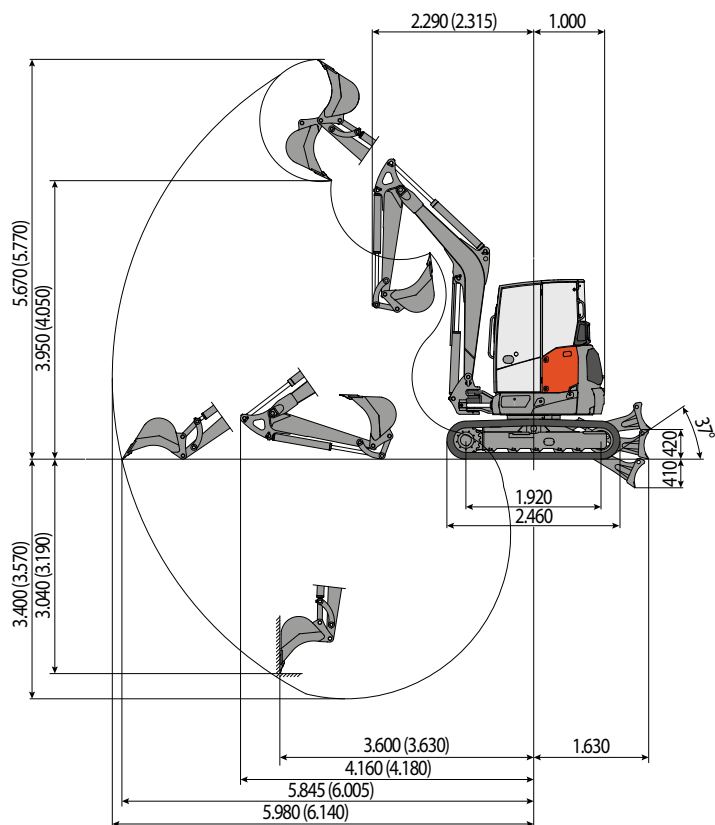

LIFTING CAPACITY

Opening arm from the rotation's center (m)
Lifting capacity (kg) at 1.0 m height

	3	4	5	MAX
Frontal and lowered dozer blade	2770	1850	1450	1410
Frontal and lifted dozer blade	1470	970	690	670
Lateral	1190	790	560	550

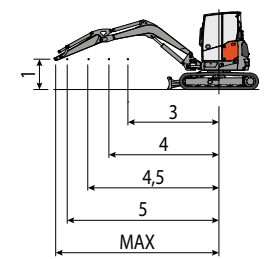

The lifting capacity is based on the ISO 10567 and it does not exceed more than the 75% of static tipping load or more than the 87% of the hydraulic lifting capacity of the machine.



Sampierana S.p.A. reserves the right to change technical data and product characteristics at any time without prior notice.