

ELEVAH[®] 40 MOVE

ELEVAH 40 MOVE

SELF PROPELLED ON THE GROUND



The **self-propelled** platform Elevah 40 MOVE is compact, nimble, easy to be driven, but above all safe.

NEW LOAD SYSTEM.
PATENTED.

(See cod. 40 CAR.1 and 40 CR on p.51)



WORK IN SAFETY

It is compact, agile and easy to drive but above all it is safe.



IDEAL IN TIGHT SPACES
Thanks to its incredible dimensions (99.5 x 99.5 cm), Elevah 40 Move is at its best in tight spaces.



ELEVAH[®] 40 MOVE

TECHNICAL DATA

ELEVAH 40 MOVE

Max. working height		4,00 m
Max capacity		150 kg
Number of people		1
Use		internal
A	Closed machine height	1630 mm
B	Minimum platform height	310 mm
C	Maximum platform height	1960 mm
D/E	Base overall dimensions	995 x 740 mm
F/G	Cage dimensions	690 x 740 mm
Machine weight		162 kg
Drive steering wheels dimensions		Ø 190 x 60
Swivel wheels dimensions (fixed)		Ø 150 x 45



PERFORMANCE

Power supply		electrical
Batteries		2 AGM 12V 33 Ah*
Battery charger		110V - 220V
H	Maximum climbing ability	15%
Internal turning radius		0
External turning radius		800 mm
Max. speed (rising – descending)		0,10 - 0,16 m/s
Velocità massima di traslazione		1,3 m/s
Work cycles ** (with fresh batteries)		Ca. 100

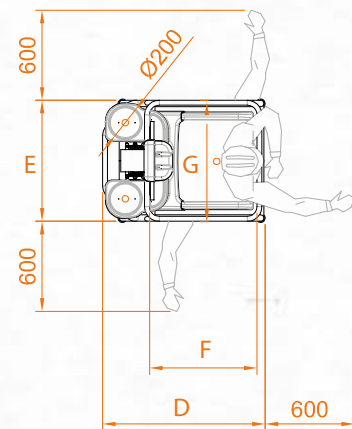

* OPTIONAL: 40BGM

** By work cycle we mean a self-propelled movement of 20 m with a full ascent to and descent from the maximum height.

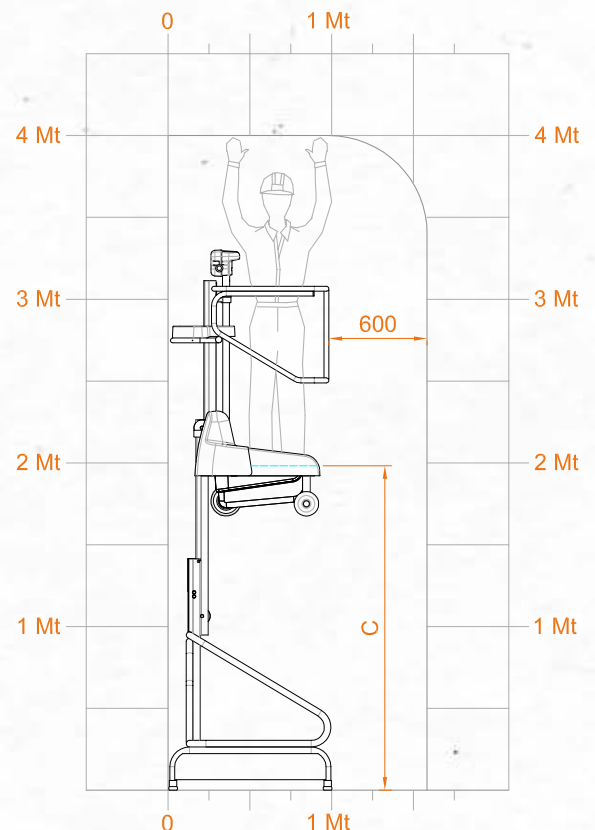
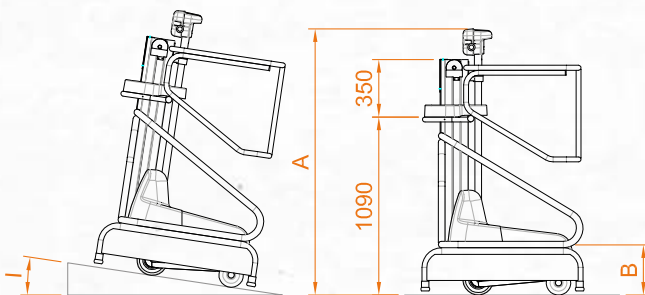

TECHNICAL DATA

