



DIECI



1000 F



1000 PA



1000 T



4200



8000

DUMPERS

GENERAL INFORMATION

Machine model	DUMPER 1000 F	DUMPER 1000 T	DUMPER 1000 PA	DUMPER 4200	DUMPER 8000
Maximum capacity	2500 kg (5512 lb)	2500 kg (5512 lb)	2500 kg (5512 lb)	8000 kg (17637 lb)	14000 kg (30865 lb)
Caisson capacity (level)	1,0 m ³ (35 ft ³)	1,0 m ³ (35 ft ³)	1,0 m ³ (35 ft ³)	4,2 m ³ (148 ft ³)	8,00 m ³ (283 ft ³)
Caisson capacity (heaped)	1,2 m ³ (42 ft ³)	1,2 m ³ (42 ft ³)	1,2 m ³ (42 ft ³)	5,3 m ³ (187 ft ³)	8,50 m ³ (300 ft ³)
Unladen weight	1200 kg (2646 lb)	1300 kg (2866 lb)	1550 kg (3417 lb)	5820 kg (12831 lb)	8430 kg (18585 lb)
Standard tires	7.5x16"	7.5x16"	7.5x16"	16/70-20"	12.00 - 24"
Max speed (referred to wheels with maximum permitted diameter)	23 km/h (14,3 mph)	23 km/h (14,3 mph)	23 km/h (14,3 mph)	27 km/h (16,8 mph)	30 km/h (18,6 mph)
Notes	Dump body with front hydraulic tipping.	Dump body with trilateral hydraulic tipping.	Dump body with front hydraulic tipping. Loading shovel with hydraulic control.	Dump body with rear hydraulic tipping.	Dump body with rear hydraulic tipping.

ENGINE

Machine model	DUMPER 1000 F	DUMPER 1000 T	DUMPER 1000 PA	DUMPER 4200	DUMPER 8000
Brand	Lombardini	Lombardini	Lombardini	Kubota	FPT
Nominal power	15 kW (20 HP)	15 kW (20 HP)	15 kW (20 HP)	83,5 kW (112 HP)	125 kW (168 HP)
@rpm	3000 rpm	3000 rpm	3000 rpm	2600 rpm	2200 rpm
Operation	4-stroke	4-stroke	4-stroke	4-stroke	4-stroke
Injection	Mechanical direct	Mechanical direct	Mechanical direct	Electronic, Common Rail	Electronic, Common Rail
Number and arrangement of cylinders	2, Vertical in line	2, Vertical in line	2, Vertical in line	4, Vertical in line	4, Vertical in line
Displacement	954 cm ³ (58 in ³)	954 cm ³ (58 in ³)	954 cm ³ (58 in ³)	3769 cm ³ (230 in ³)	4485 cm ³ (274 in ³)
Emission standards	Stage IIIA/Tier 3	Stage IIIA/Tier 3	Stage IIIA/Tier 3	Stage IIIB/Tier 4i	Stage IIIB/Tier 4i
Cooling system	Air	Air	Air	Liquid	Liquid
Intake	Natural	Natural	Natural	Turbo compressor after-cooler	Turbo compressor 16 valve

TRANSMISSION

Machine model	DUMPER 1000 F	DUMPER 1000 T	DUMPER 1000 PA	DUMPER 4200	DUMPER 8000
Transmission type	Single-plate dry clutch	Single-plate dry clutch	Single-plate dry clutch	Hydrostatic with variable flow pump	Hydrostatic with variable displacement pump
Transmission gearbox	4-Gear with reversing mechanism	4-Gear with reversing mechanism	4-Gear with reversing mechanism	Servocontrolled 2-speed	Servo-controlled 2-speed

DIFFERENTIAL AXLES

Machine model	DUMPER 1000 F	DUMPER 1000 T	DUMPER 1000 PA	DUMPER 4200	DUMPER 8000
Axles type	2 rigid	2 rigid	2 rigid	2 steering, with 4 planetary reduction gears	2 steering, with 4 epicycloidal reduction gears
Type of steering	With articulated chassis	With articulated chassis	With articulated chassis	4 wheels / transversal / 2 wheels	4 wheels / transversal / 2 wheels
Service braking	Hydraulic	Hydraulic	Hydraulic	Oil bath on front and rear axle	Oil bath with servo brake on front and rear axle
Parking braking	Mechanical with lever	Mechanical with lever	Mechanical with lever	Acting on the rear axle	Acting on the front axle

DRIVER'S SEAT and CANOPY

Machine model	DUMPER 1000 F	DUMPER 1000 T	DUMPER 1000 PA	DUMPER 4200	DUMPER 8000
Cab description	Power steering, adjustable seat.	Power steering, adjustable seat.	Power steering, adjustable seat.	Reversible driving seat, adjustable seat with seat belts, front and rear windows, 2 window wipers.	Reversible driving seat, adjustable seat with seat belts, front and rear windows, 2 window wipers.
Cab instrumentation	Oil, battery charge indicator light.	Oil, battery charge indicator light.	Oil, battery charge indicator light.	Fuel level gauge, oil and water temperature indicator light, battery charge indicator light, hour meter.	Fuel level gauge, oil and water temperature indicator light, battery charge indicator light, hour meter.
Cab approval	ROPS - FOPS approved roof	ROPS - FOPS approved roof	ROPS - FOPS approved roof	ROPS - FOPS	ROPS - FOPS

DIMENSIONS

Machine model	DUMPER 1000 F	DUMPER 1000 T	DUMPER 1000 PA
A	270 mm (10,6 in)	270 mm (10,6 in)	270 mm (10,6 in)
A1	2450 mm (96,5 in)	2450 mm (96,5 in)	2450 mm (96,5 in)
B	650 mm (25,6 in)	650 mm (25,6 in)	650 mm (25,6 in)
B1	3100 mm (122 in)	3100 mm (122 in)	3100 mm (122 in)
C	1950 mm (76,8 in)	1950 mm (76,8 in)	1950 mm (76,8 in)
C1	4020 mm (158,3 in)	4020 mm (158,3 in)	4020 mm (158,3 in)
D	500 mm (19,7 in)	500 mm (19,7 in)	500 mm (19,7 in)
F	2840 mm (111,8 in)	2840 mm (111,8 in)	2840 mm (111,8 in)
G	3100 mm (122 in)	3100 mm (122 in)	3100 mm (122 in)
H	2520 mm (99,2 in)	2520 mm (99,2 in)	2520 mm (99,2 in)
I	1320 mm (52 in)	1320 mm (52 in)	1320 mm (52 in)
L	1400 mm (55,1 in)	1400 mm (55,1 in)	1400 mm (55,1 in)
M	1600 mm (63 in)	1600 mm (63 in)	1680 mm (66,1 in)
P	2850 mm (112,2 in)	2850 mm (112,2 in)	2850 mm (112,2 in)
Q	4500 mm (177,2 in)	4500 mm (177,2 in)	4500 mm (177,2 in)
V	1450 mm (57,1 in)	1450 mm (57,1 in)	1450 mm (57,1 in)
Z	2125 mm (83,7 in)	2125 mm (83,7 in)	2125 mm (83,7 in)
K02	30°	30°	30°
K03	10°	10°	10°

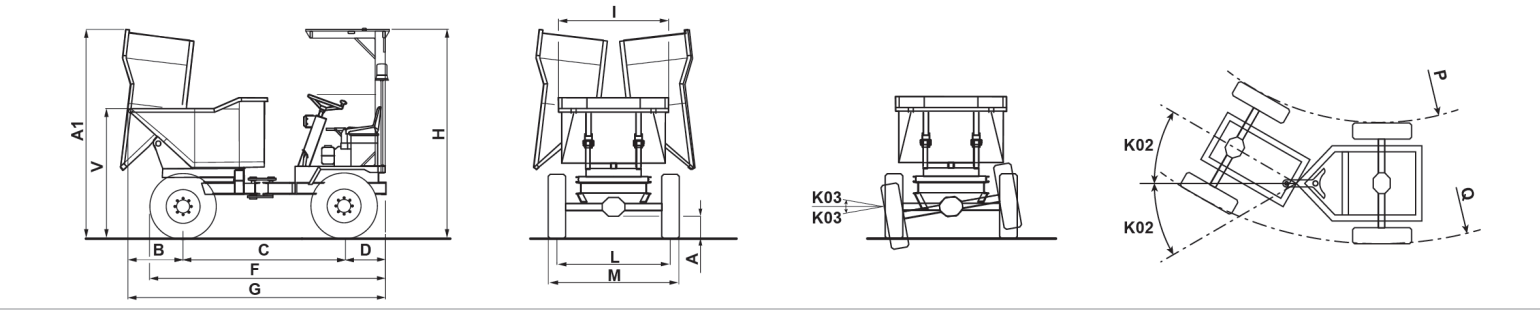
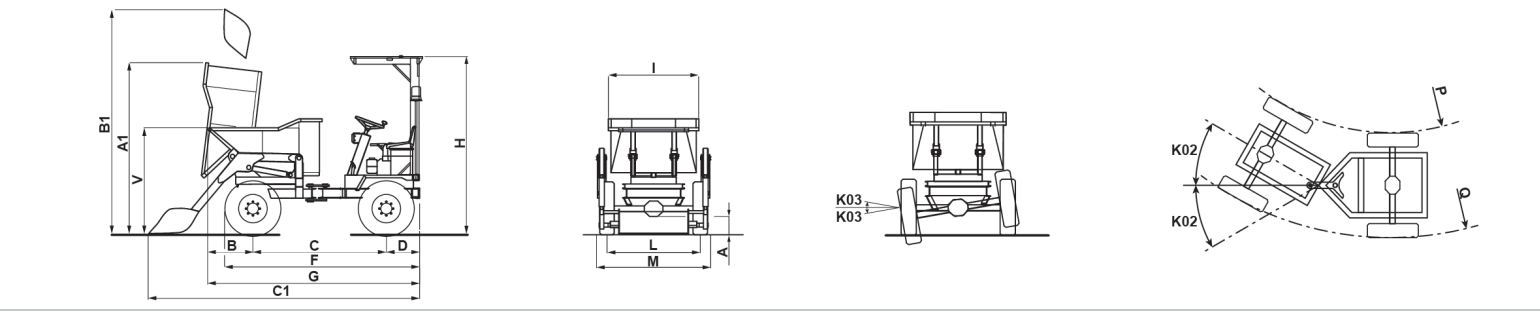
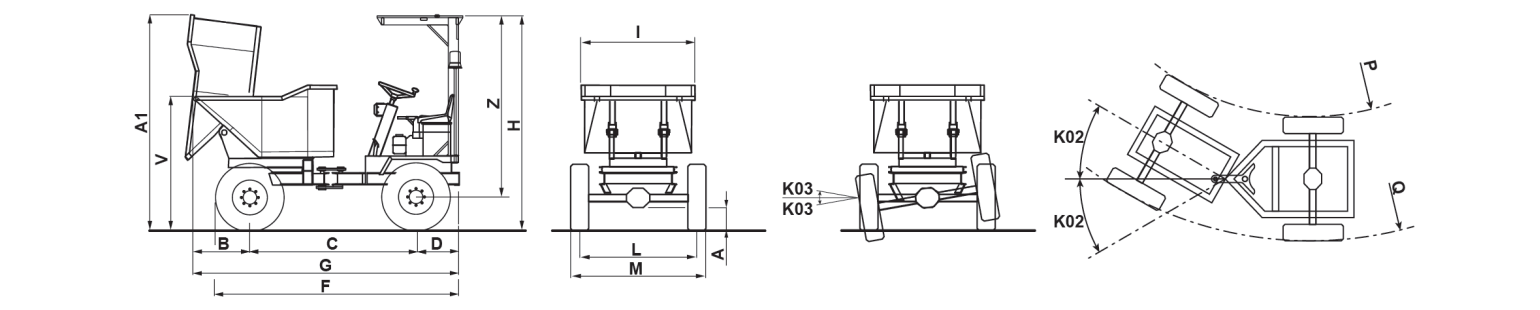

DIMENSIONS

Machine model	DUMPER 4200	DUMPER 8000
A	408 mm (16,1 in)	602 mm (23,7 in)
A1	3797 mm (149,5 in)	4698 mm (185 in)
B	1370 mm (53,9 in)	1230 mm (48,4 in)
C	2600 mm (102,4 in)	3430 mm (135 in)
D	1005 mm (39,6 in)	807 mm (31,8 in)
F	4686 mm (184,5 in)	5467 mm (215,2 in)
G	4980 mm (196,1 in)	5841 mm (230 in)
H	2935 mm (115,6 in)	3160 mm (124,4 in)
I	1005 mm (39,6 in)	1005 mm (39,6 in)
L	2000 mm (78,7 in)	2020 mm (79,5 in)
M	2408 mm (94,8 in)	2380 mm (93,7 in)
N1	2295 mm (90,4 in)	2495 mm (98,2 in)
S	2107 mm (83 in)	2684 mm (105,7 in)
P	2787 mm (109,7 in)	3188 mm (125,5 in)
Q	5260 mm (207,1 in)	5876 mm (231,3 in)
R	5700 mm (224,4 in)	6260 mm (246,5 in)
S	83 in (2107 mm)	105,7 in (2684 mm)
U	2410 mm (94,9 in)	2410 mm (94,9 in)

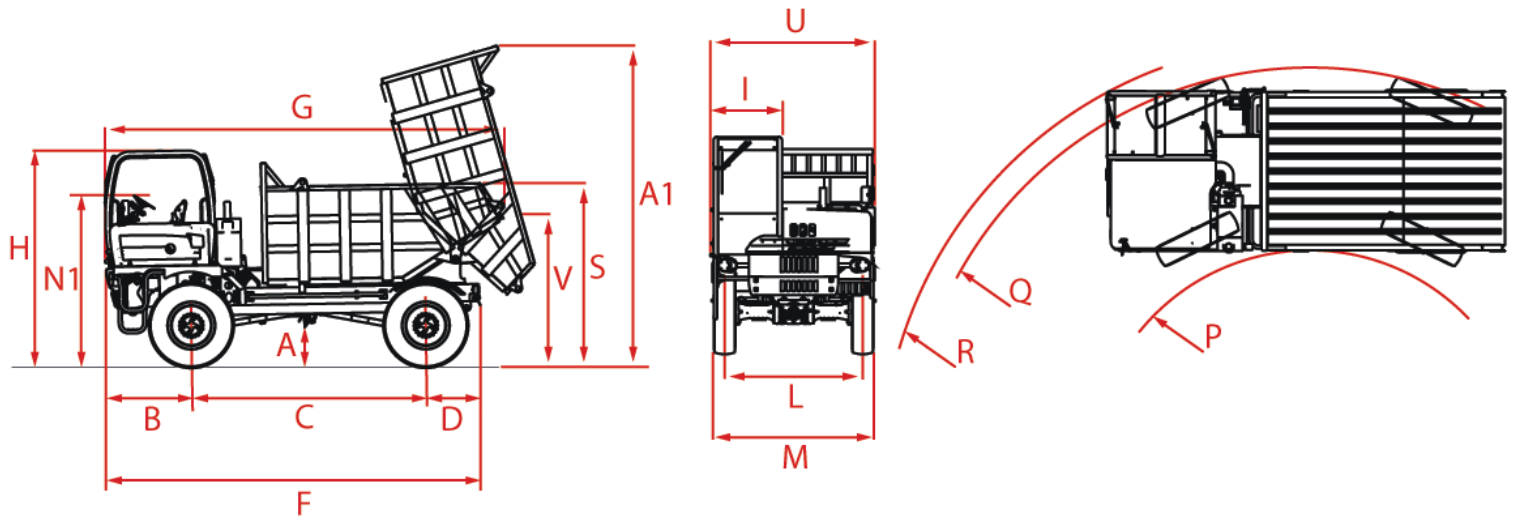

Dieci Srl - Via E. Majorana, 2-4 – 42027 – Montecchio Emilia (RE) ITALY

Tel. +39 0522 869611 – Fax +39 0522 869798 – E-mail: info@dieci.com – www.dieci.com

SKT Dumpers EC -UK | v. 1.5