

ELEVAH[®] 40 B picking



The picking machine with an elevation of up to 4 metres, having **manual traction** and **automatic elevation** with a 24-volt battery.



EXTENDIBLE
PICKING PLATFORM



PUSH AROUND MACHINE



PUSH AROUND MACHINE - MAX. WORKING HEIGHT 4 M

CE Complies with European regulations for man-up forklift trucks.
UNI EN ISO 3691-1.



Faraone
Industrie spa

ELEVAH 40B PICKING

STOCK PICKERS

ELEVAH[®] 40B picking

TECHNICAL DATA

Max. working height		4,00 m
Max capacity		150 kg
Number of people		1
Use		Internal - External
A	Closed machine height	1630 mm
B	Minimum platform height	310 mm
C	Maximum platform height	1960 mm
D/E	Base overall dimensions	995 x 740 mm
F/G	Cage dimensions	690 x 740 mm
Machine weight		162 kg
Fixed picking tray dimensions		270 x 630 mm
Driving (steering) wheel size		Ø 200 x 50
Swivel wheels dimensions (fixed)		Ø 150 x 45

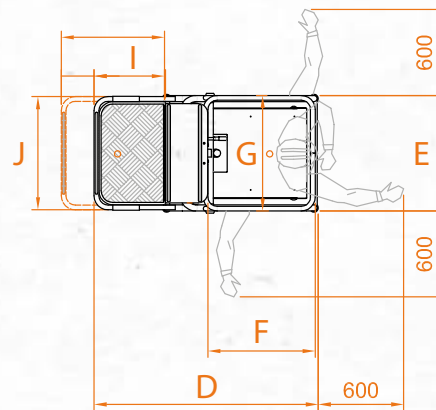

PICKING PLATFORM

Adjustment		meccanica
H	Stroke	710 mm
Min. height from the ground		850 mm
Max. height from the ground		3100 mm
I/J	Dimensions	450 (660) x 725 mm
Capacity		40 kg

PERFORMANCE

Batteries		2xAGM - 12 V 33 Ah
Battery charger		110V - 220V
K	Maximum climbing ability	15%
Max. speed (rising - descending)		0,10 - 0,16 m/s
Work cycles * (with fresh batteries)		Ca. 100

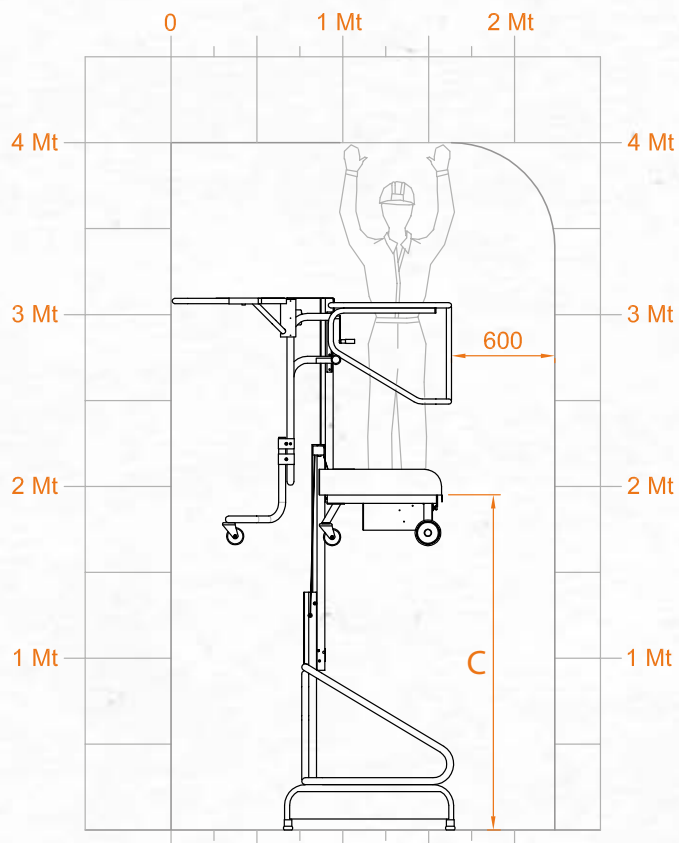

* By work cycle we mean a self-propelled movement of 20 m with a full ascent to and descent from the maximum height.

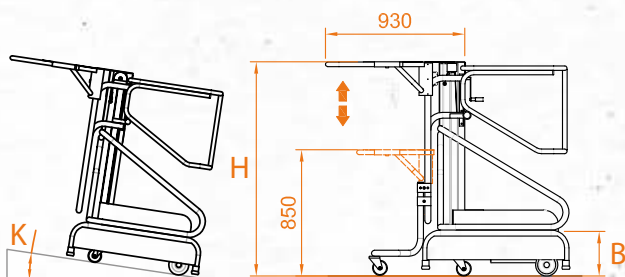

ELEVAH 40B PICKING

TECHNICAL DATA