

STAR 6

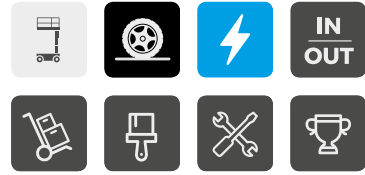

GO EVERYWHERE

- > High precision driving & smoothness
- > Quick machine
- > Comfort & agility
- > Indoor / outdoor rated (versatile)
- > Easy access to the platform
- > Smart transportability & lifting

WITH THE BEST VALUE FOR MONEY

- > Robust machine
- > Smart mast system
- > Minimal maintenance & downtime
- > Direct electric drive with brushless AC motors
- > Easy access to components
- > Haulotte Activ'Screen (onboard diagnostic)



VERTICAL MASTS

TECHNICAL DATA

STAR 6

Working height	5.8 m
Platform height	3.8 m
Lift capacity - inside	230 kg (2 pers.)
Lift capacity - outside	230 kg (1 pers.)
Platform size	0.77 x 1.38 m
A Length	1.4 m
B Width	0.79 m
C Height - stowed	1.75 m
D Wheelbase	1.06 m
E Ground clearance	6 cm
Drive speed proportional	0.8 - 4.5 km/h
Turning radius - outside	1.7 m
Tilt alarm	1.5 ° / 3 °
Gradeability	25 %
Driveable at full height up to	3.8 m
Tyres - non marking	318 x 108
Power source	12 V - 105 Ah (C5)
Weight	835 kg

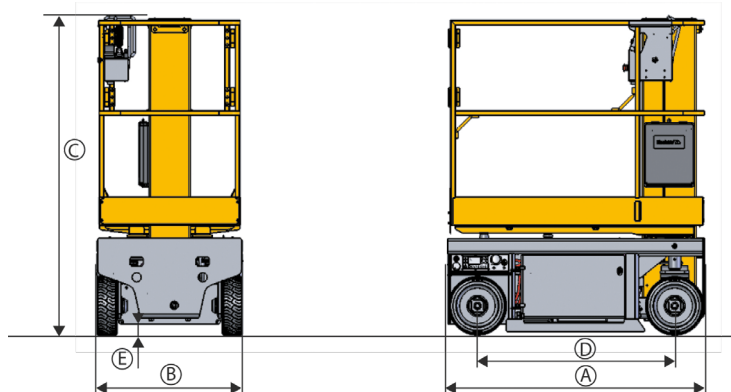

STANDARD EQUIPMENT

- > 24 V electric drive brushless AC motors
- > 2 x 12 V - 105 Ah batteries
- > 20 A battery charger
- > Battery charge indicator
- > Haulotte Activ'Screen
- > Fork lifting pockets
- > Hoisting and lifting points
- > Swing door entry gate
- > Mobile potholes
- > 2 front steering wheels
- > 2 rear driving wheels
- > Non marking tyres
- > Brake release
- > Hourmeter
- > Horn
- > Travel alarm
- > Emergency stop
- > Emergency hand pump
- > 2 control stations at cage and ground level
- > Mobile upper control box
- > 2 towing hooks
- > Protection baseboard

OPTIONS AND ACCESSORIES

- > Upper control box protection cover
- > Tool tray
- > Platform extension deck + 0.4 m / + 1 ft 4 in (height stowed: 1.8 m / 5 ft 11 in) (standard in AUS / NZ)
- > Power line in platform
- > Ground-fault circuit interrupter 30 mA
- > Telematics ready
- > Biodegradable oil
- > Hydraulic oil for cold countries
- > Flashing light (standard in AUS / NZ)
- > Fluorescent tube caddy

